

EasyStart™

Installation Instructions for Dometic® Family RV A/Cs

DuoTherm®

Brisk®

Brisk® II

Penguin®

Penguin® II

Blizzard NXT®

Contents

Introduction.....	4
Safety first.....	4
Making a good crimp.....	4
Identifying Dometic AC Units.....	5
Opening the cover.....	5
Identifying the compressor and run capacitor.....	6
High-profile models.....	6
Low-profile and NXT models.....	6
Run capacitor terminals.....	6
Roof top RV installation kit.....	7
Part number: KIT-364-RT2.....	7
Brisk I.....	8
Wiring diagram.....	8
Mounting location.....	9
Installing the box:.....	9
Making the connections.....	10
Brown wire.....	10
White wire.....	10
Orange wire.....	10
Black wire.....	11
Removing existing start components.....	11
Brisk II.....	12
Wiring Diagram.....	12
Mounting Location.....	13
Installing the box:.....	13
Making the connections.....	14
Brown wire.....	14
White wire.....	14
Orange wire.....	14
Black wire.....	15
Removing existing start components.....	15
Penguin I and II.....	16
Wiring Diagrams.....	16
Penguin II Mounting Location.....	17
Penguin II Suction Tubes.....	18

Mounting for older Penguin AC units	19
Routing the wires (most Penguin I and II models).....	20
Making the connections.....	21
Brown wire	21
White wire	21
Orange wire	21
Black wire.....	21
Removing existing start components.....	22
Blizzard NXT.....	22
Wiring Diagrams	22
NXT Mounting Location.....	23
Routing the wires	24
Making the connections.....	25
Brown wire	25
White wire	25
Orange wire	25
Black wire.....	25
Removing existing start components.....	26
Learning process	26
Troubleshooting FAQ	27
How do I know I installed it correctly?	27
Nothing works, not even the fan.....	27
The fan runs but it won't start on utility power.	27
I did everything in the last FAQs and it still will not start. What next?	27
My air conditioner runs great on commercial electric power but will not start on my generator.....	27
My air conditioner shuts off early on generator. What can be wrong?.....	27

Introduction

Dometic air conditioners are used throughout the RV industry for many years. EasyStart is a great companion to minimize the startup current surges on these units, thus making it possible to operate the A/C on a limited power source, such as a generator or inverter.

The information contained in this manual can be used to install EasyStart on most Dometic brand air conditioning units. Similar models are grouped together as the installation is very comparable for these units.

Safety first

The voltage inside the air conditioner can cause severe injury or death if improperly handled. Read all safety precautions before proceeding.

- An air conditioner is a high voltage AC device that can cause a dangerous or even fatal electric shock.
- Follow all electrical safety guidelines for your locality when working with your air conditioner.
- Always be sure power is completely removed from the entire RV or boat before working on the air conditioner.
- If you are uncomfortable working on your air conditioner, please seek professional help from RV dealers, electricians or HVAC service installers to complete the installation of this product.
- Many air conditioners are installed on the top of RV's where there is a significant risk of falling. Be sure to mitigate that risk where ever possible and use safety equipment and assistance where required.

Making a good crimp

Good crimps are essential for a long-lasting, reliable installation. There are many informative guides, videos and tool recommendations on the internet. Please consult this excellent reference if you are unfamiliar with crimping connectors or need to purchase a tool.

Moderately tug on the crimp joint after making your crimp to be sure the joint was properly made. If the wire pulls out, the joint was not done correctly and must be redone. It is better to test every joint during the install than to find out on a hot day that the crimp failed!

Identifying Dometic AC Units

Dometic roof top air conditioners can be broken up into two categories, low-profile (Figure 1) or high-profile (Figure 2), with a third Blizzard NXT (Figure 3, later referred to in this document as the “NXT”), somewhere between them. Older units were also called Duo-Therm and were also either low-profile or high-profile. Older low-profile unit were called the Penguin (later referred to in this document as the “Penguin I”), and the newer ones are call the Penguin II. Older high-profile units were called the Brisk (later referred to in this document as the “Brisk I”), and newer ones are called the Brisk II.



Figure 1



Figure 2



Figure 3

Opening the cover

All installation is done inside the rain cover of the air conditioner on top of the RV. The first step is to turn off power to the RV. The cover is held in place with four screws, two on each end. Remove the four screws and remove the cover. Place the cover and screws out of the way so you can safely work on the air conditioner.

Identifying the compressor and run capacitor

The compressor is shown in Figure 4. The blue arrow points to the cap over the compressor wiring. There is no need to remove this cap for installation however the wires that exit the cap must be followed to ensure the proper connections are made.

Follow the black wire pointed to by the green arrow until the wires exit the black wire jacket. The wires exiting will be colored red, blue, and white. The white and red wires will always lead to the compressor run capacitor inside the electric box. Follow the wires to locate the electric box on your air conditioner. Note that the wires may not have a wire jacket cover and can exit the compressor cap as three separate wires colored red, blue, and white.



Figure 4

High-profile models

The blue wire will go inside the air conditioner where it will connect to the thermostat relay. You will need to make a connection somewhere along the Blue wire later in these instructions.

Low-profile and NXT models

The blue wire will usually go into the electric box containing the run capacitor. Some models have a control board inside this box and the blue wire will connect to a relay on the control board. Other models have no control board and the wire passes through this box to the underside of the air conditioner.

Run capacitor terminals

All air conditioners use a split style run capacitor as shown in Figure 5. Terminal identifiers are usually stamped into the top of the capacitor. The “C” terminal or common terminal has several white wires plugged into it. The HERM terminal has one or more red wires connected. Although not visible, the FAN terminal is also labeled and has a single brown wire connected.

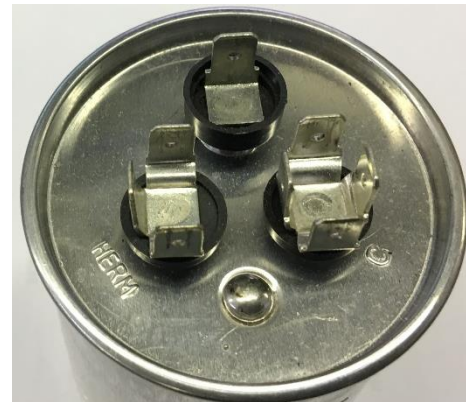

Figure 5

Roof top RV installation kit

Part number: KIT-364-RT2

This installation kit is designed for customers doing their own installation of EasyStart. It supports most rooftop RV and under cabinet models.

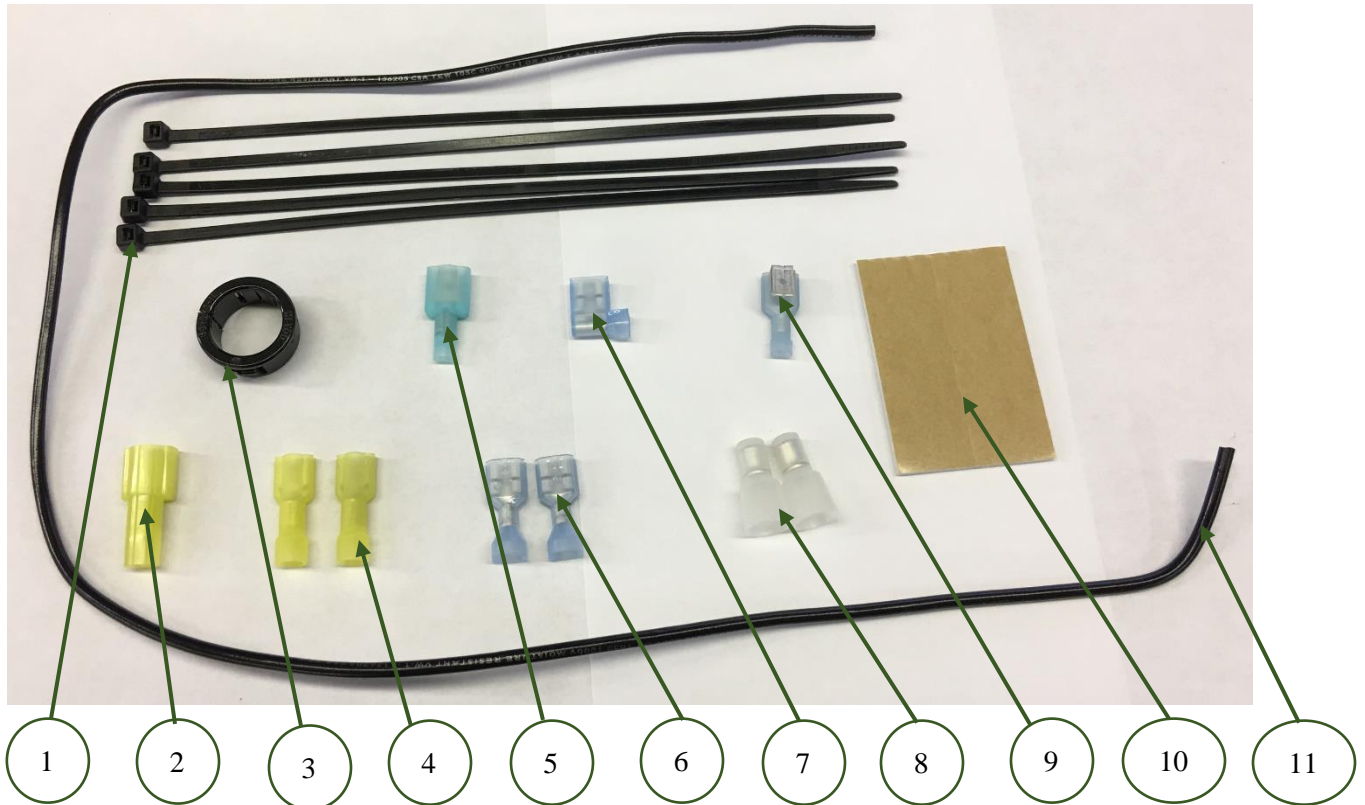

Figure 6

1. (5) Zip ties
2. (1) Male yellow quick disconnect
3. (1) Snap bushing (Used in Dometic Penguin II only)
4. (2) Female yellow quick disconnect
5. (1) Male blue quick connect
6. (2) Female blue angled quick connect
7. (1) Female angled quick connect
8. (2) End splice connector
9. (1) Piggyback connector
10. (1) Double sided foam tape
11. (1) Two feet (61cm) 14AWG wire.

Brisk I

Wiring diagram

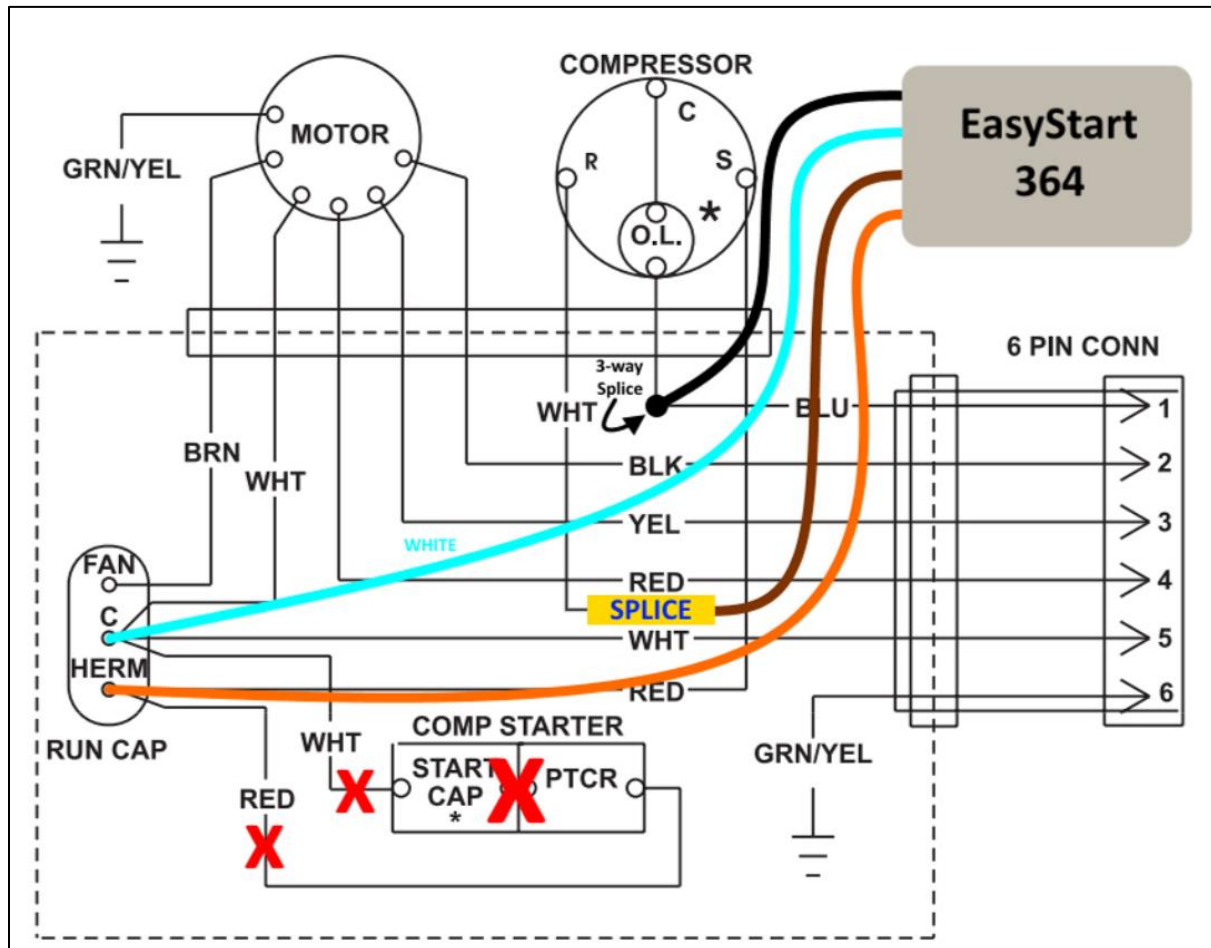

Figure 7

Figure 7 shows the typical wiring diagram supplied with the Brisk I. The red X's indicate components that will be removed during installation of EasyStart. The white wire from EasyStart is drawn in blue for contrast.

The brown wire shows a splice connection. This connection was removed from the C terminal of the run cap and connected to the brown wire.

Mounting location

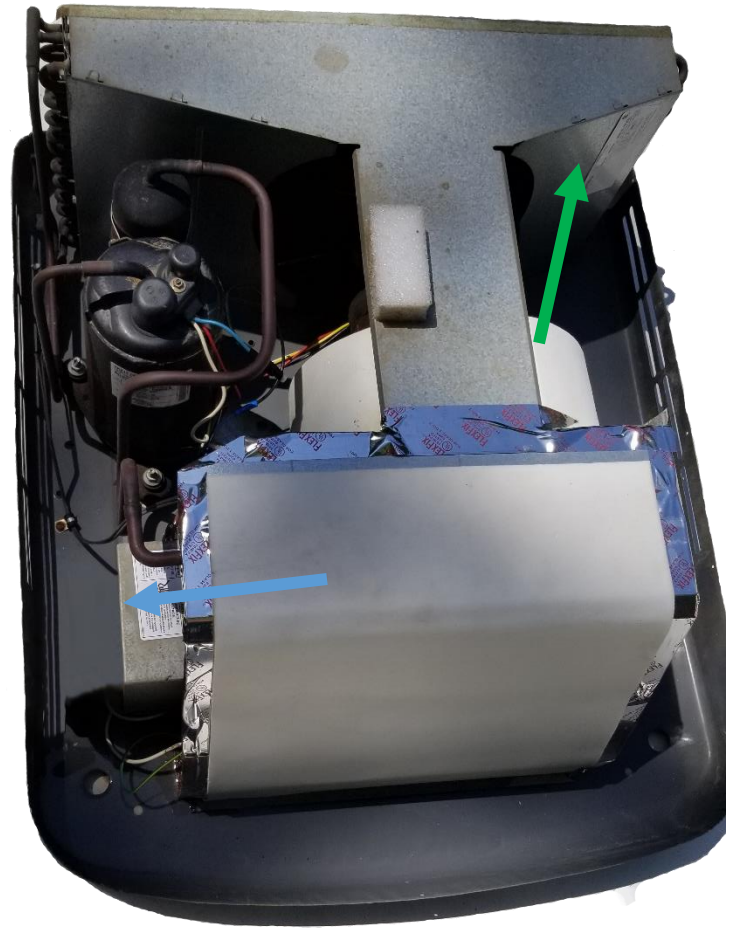

Figure 8

Two possible mounting locations are available as indicated by the arrows in Figure 8. Install EasyStart in one of these locations with the enclosure wire exit pointing down. The green arrow points to the sheet metal surface opposite the compressor. Route the wires under the fan and along the same route as the fan wires into the electric box by the blue arrow. The blue arrow points to an area on top of the cover of the electric box.

Installing the box: Clean the surface of the mounting location and the bottom of the enclosure. Place the foam tape included in the installation kit on the enclosure and mount the box.

Making the connections

Use only end splice or jacketed spade connectors for connecting one wire to another. Wire nuts can come off in this high vibration environment and automotive connectors are not rated for line voltage.

Brown wire

Follow the white wire from the compressor into the electric box to the top of the run capacitor as indicated by the green arrow in Figure 9. Disconnect the white wire and cut off the connector on the end. Strip about ½ inch (1.27cm) of insulation from the white wire and from the BROWN wire from EasyStart. Twist both wires together and crimp them with an end splice connector as shown in Figure 10.



Figure 10

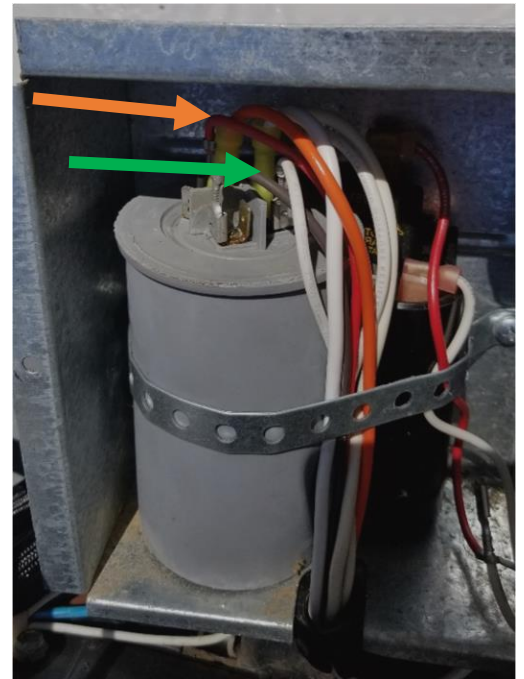

Figure 9

Note: Some installations will have multiple white wires on the terminal group. Be sure to follow the white wire from the compressor completely back to the run capacitor.

White wire

Place a yellow female quick-connect terminal on the WHITE wire from EasyStart and crimp tightly. Connect the WHITE wire from EasyStart to the run capacitor on the same terminal group as the other white wires on the “C” terminal.

Orange wire

Place a blue female quick-connect terminal on the ORANGE wire from EasyStart and crimp it tightly. Connect the ORANGE wire to the red wire terminal group on run capacitor shown by the orange arrow in Figure 9.

Black wire

Strip about ½ inch (1.27cm) of insulation from both the black wire from EasyStart and the extra black wire that comes in the installation kit. Connect the two wires together using an end splice. Route the wire outside the box to a location near the wire exit on the compressor.

Cut the blue wire shown in Figure 11 at a convenient location to make a splice. Be sure to leave enough wire to easily make a crimp. Strip about ½ inch (1.27cm) of insulation from both the black and two blue wires and twist the three wires together. Securely crimp the three wires together using a new end splice as shown in Figure 12.



Figure 12



Figure 11

Removing existing start components

Some systems may use a start cap (orange arrow in Figure 13) and PTCR (green arrow in Figure 13). Previous owners may have also installed a hard start kit that replaces these components. These components form a circuit that connect from the white wire group on the run capacitor to the red wire group on the run capacitor.

Figure 14 shows a single red wire connecting to the run capacitor. If your system has only this single red wire then there are no start components in your system so skip the rest of this section.

If there is another wire connected to the red wire group on the run capacitor (other than the orange wire from EasyStart), remove the wire and disconnect it from the component it connects to. If the end of the wire is directly connected to the PTCR (such as a different style PTCR than shown in Figure 13), disconnect the PTCR wire on the other side of the PTCR from the start capacitor as well.



Figure 14



Figure 13

Brisk II

This unit can be identified by the black foam used instead of metal framework. The foam may be carefully removed for cleaning the coil or accessing additional wiring.



Figure 15

Wiring Diagram

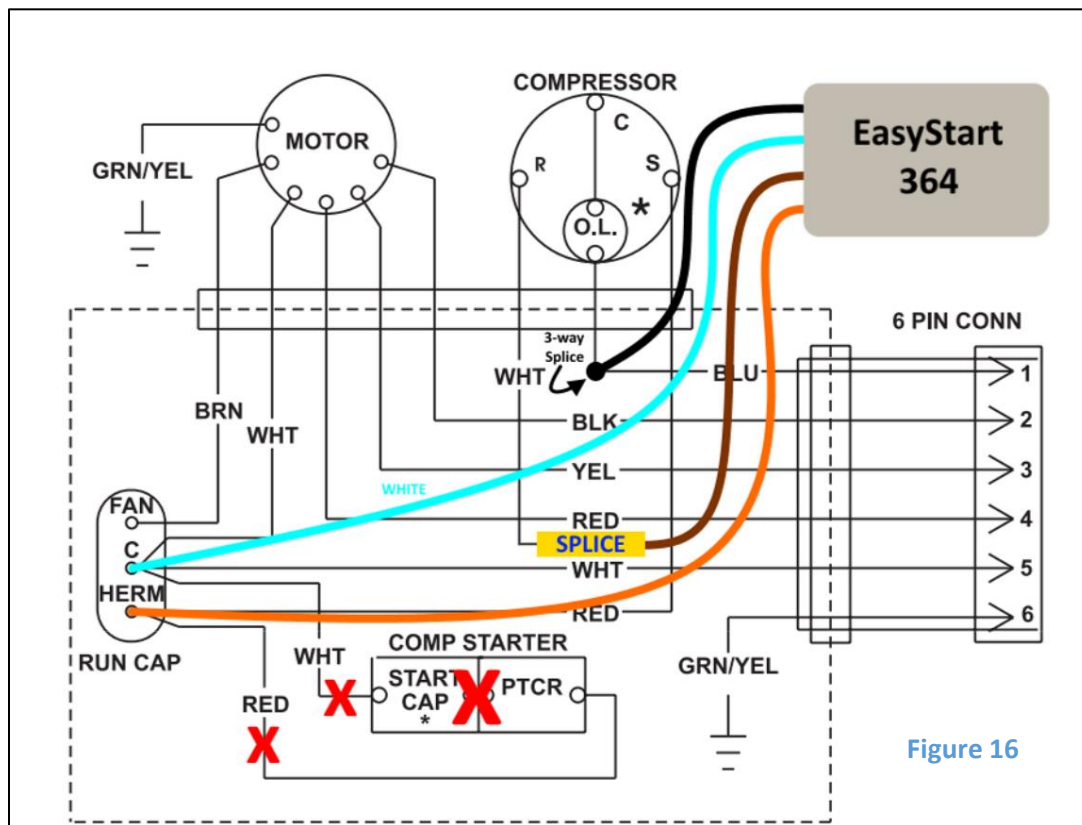

Figure 16

Figure 16 shows a quick synopsis of the changes made to the wiring. The red X's show the compressor start capacitor and PTCR that will be removed during installation. Please note that many if not all Brisk II models do not have a compressor start capacitor or PTCR so this can be ignored in most installations. To be sure, simply check the red wire terminal (HREM terminal) on the run capacitor. If you have only one red wire and no other wires, there is no start circuitry to remove.

Mounting Location

Figure 17 shows a typical mounting location for EasyStart. It can also be mounted vertically next the electric box with the wire exit pointed down. ***Always install EasyStart with the wire exit parallel to the ground or pointing down. Never install EasyStart with the wire exit pointing up.***

Installing the box:

Clean the surface of the mounting location and the bottom of the enclosure. Place the foam tape included in the installation kit on the enclosure and mount the box.

Alternately, you can use standard zip ties to mount the box through the air conditioner frame as shown in Figure 17.



Figure 17

Making the connections

Use only end splice or jacketed spade connectors for connecting one wire to another. Wire nuts can come off in this high vibration environment and automotive connectors are not rated for line voltage.

Brown wire

Follow the white wire from the compressor into the electric box to the top of the run capacitor as indicated by the green arrow in Figure 18. Disconnect the white wire and cut off the connector on the end. Strip about ½ inch (1.27cm) of insulation from the white wire and from the BROWN wire from EasyStart. Twist both wires together and crimp them with an end splice connector as shown in Figure 19.



Figure 19



Figure 18

Note: *Some installations will have multiple white wires on the terminal group. Be sure to follow the white wire from the compressor completely back to the run capacitor.*

White wire

Place a yellow female quick-connect terminal on the WHITE wire from EasyStart and crimp tightly. Connect the WHITE wire from EasyStart to the run capacitor on the same terminal group as the other white wires on the “C” terminal.

Orange wire

Place a blue female quick-connect terminal on the ORANGE wire from EasyStart and crimp it tightly. Connect the ORANGE wire to the red wire terminal group on run capacitor shown by the orange arrow in Figure 18.

Black wire

Strip about ½ inch (1.27cm) of insulation from both the black wire from EasyStart and the extra black wire that comes in the installation kit. Connect the two wires together using an end splice. Route the wire outside the box to a location in the foam compartment near on the compressor as shown in Figure 20.

Cut the blue wire shown in Figure 20 at a convenient location to make a splice. Be sure to leave enough wire to easily make a crimp. Strip about ½ inch (1.27cm) of insulation from both the black and two blue wires and twist the three wires together. Securely crimp the three wires together using a new end splice as shown in Figure 21.

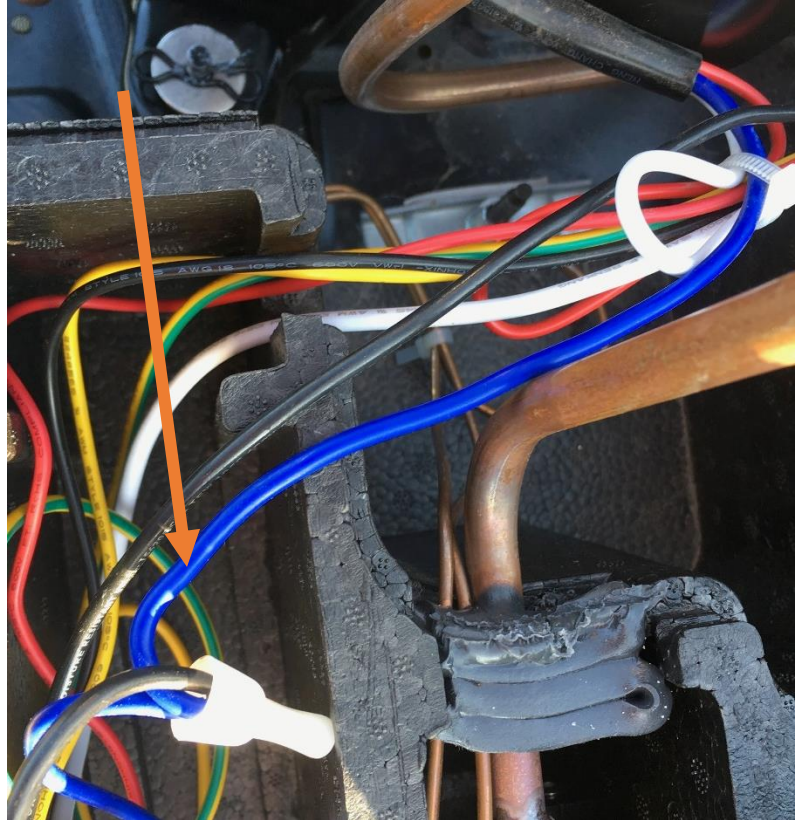

Figure 20



Figure 21

Removing existing start components

Most Brisk II systems do not use start components. To verify this, check the red wire terminal group also called HERM terminal on the run capacitor. There should only be one wire on that terminal group and it should be red in color. If that description matches your system, please skip to the learning process.

If you find your compressor has more than one wire on the HERM terminal group, remove the wire that does NOT go to the compressor. Follow that wire, disconnect it at the other end and remove it.

Sometimes the wire will connect to a PTCR where the wire is part of the component. If you have this style device, follow the wire on the other side of the PTCR and disconnect that wire as well. Tie the wires out of the way with a zip tie or remove the PTCR device completely from the electric box.

Penguin I and II

The Penguin I and II are similar in construction and physical wiring. If you have followed the instructions under “Identifying the compressor and run capacitor”, you will have found the electrical box on one side of the enclosure covered by a metal plate. Remove the plate to expose the components.

Wiring Diagrams

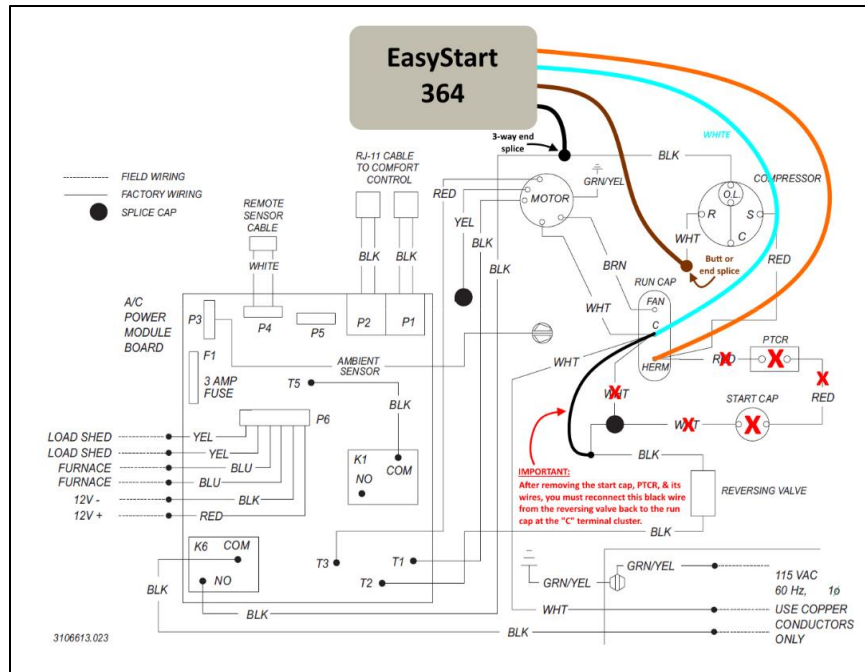

Figure 22

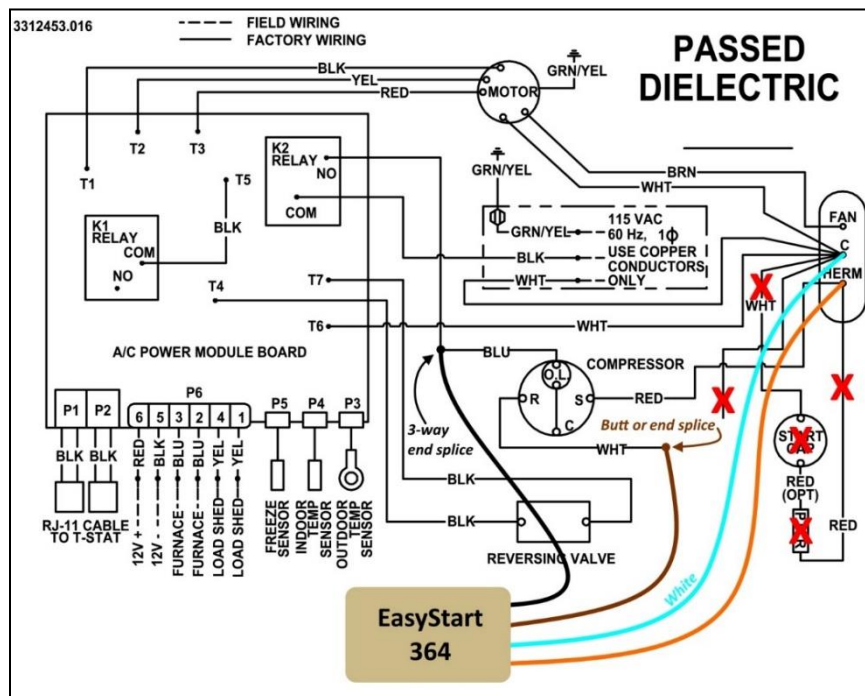

Figure 23

Figure 22 and Figure 23 are schematics from Penguin I and II respectively. The wiring is the same however some earlier penguin I compressors may use a black wire for the common wire connection instead of the blue wire shown with the Penguin II. The red X's indicate connections that are to be removed or changed when installing EasyStart.

Figure 22 shows a heat pump option with a special consideration. If you have a heat pump and there is more than 1 wire on either terminal of the start capacitor, move this third reversing valve wire (usually a black or purple wire) to the "C" terminal on the run capacitor when disconnecting the start capacitor as shown.

Penguin II Mounting Location

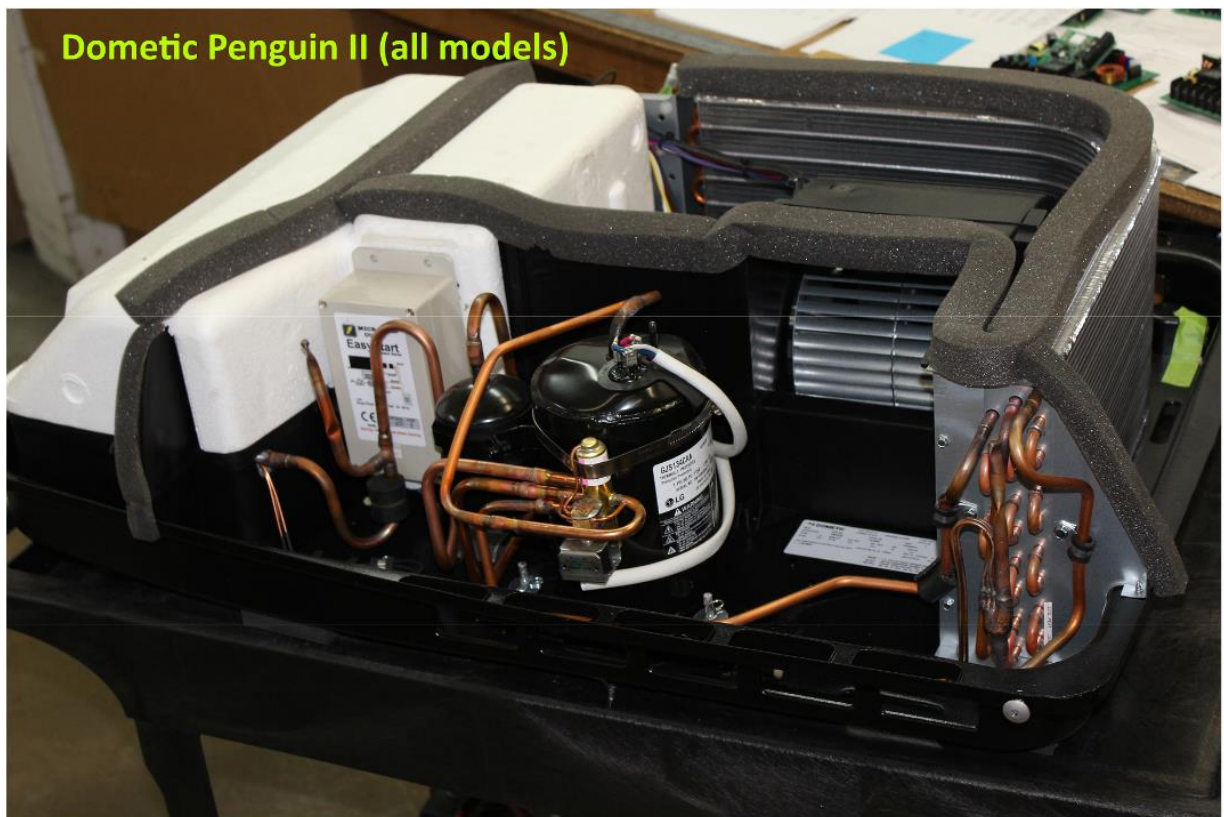

Figure 24

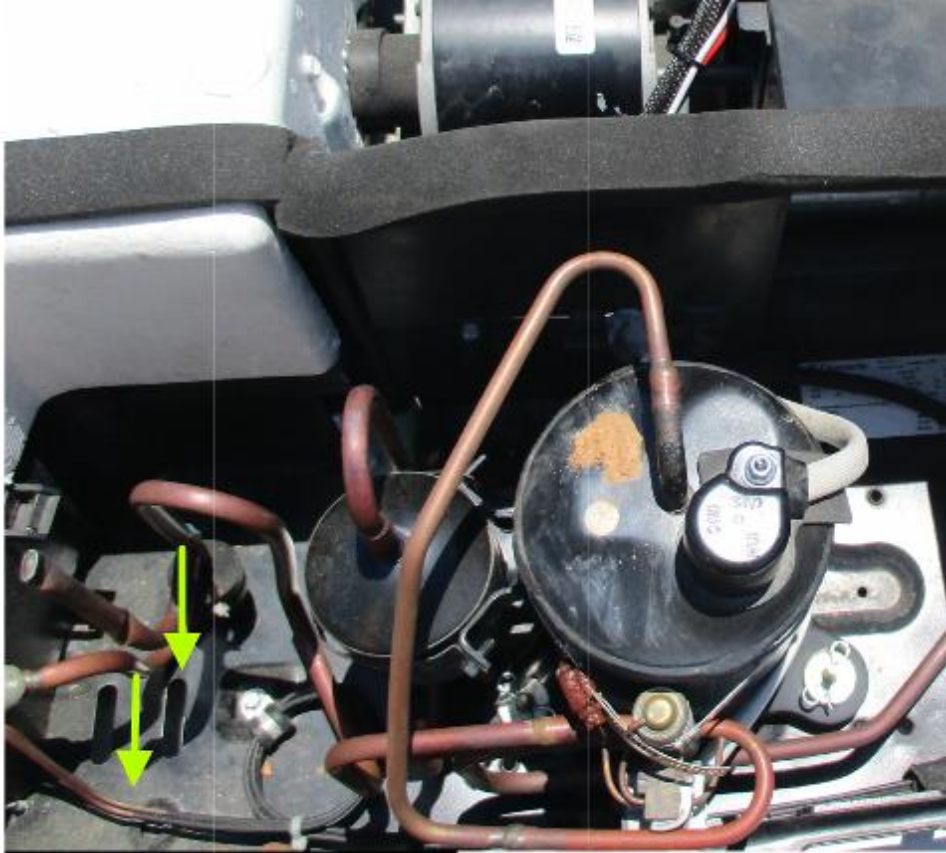

Figure 25

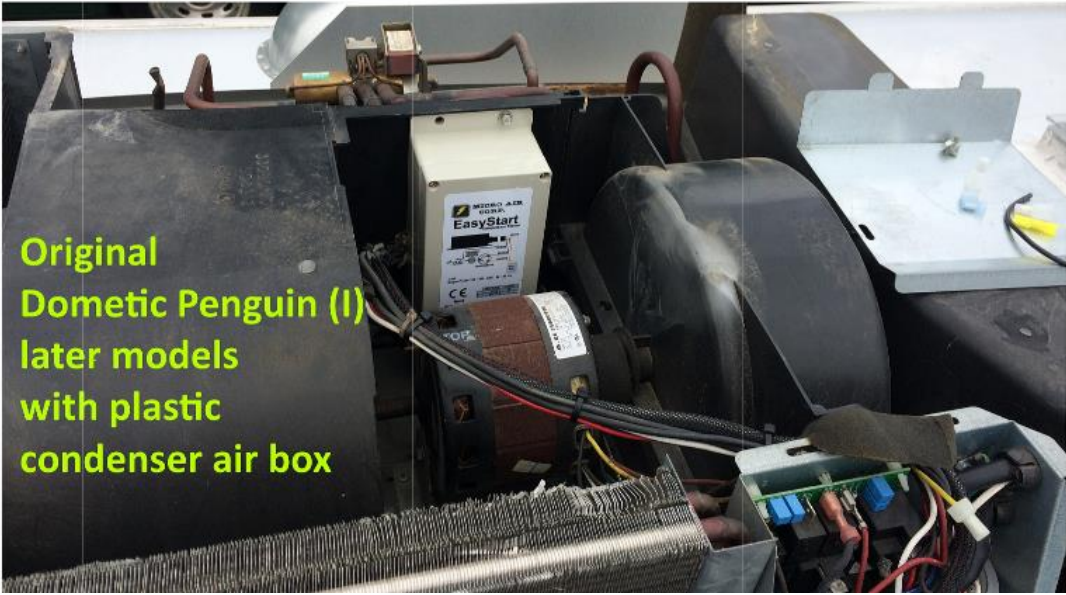

Figure 26

Penguin II Suction Tubes

Some Penguin II air conditioners were manufactured with the tubes angled more than others. If your unit has the bent tubes as shown in Figure 25 that prevents installing EasyStart, carefully bend the soft copper tubes out as shown. The rubber damper can be moved around for some additional clearance, shown in Figure 26.

Mounting for older Penguin AC units



Routing the wires (most Penguin I and II models)

Pull back the grey putty around the compressor wires passing through the plastic air box separator in Figure 27. Pass the braided wires from EasyStart through the hole and form the putty back around the wires and over the hole.



Figure 27

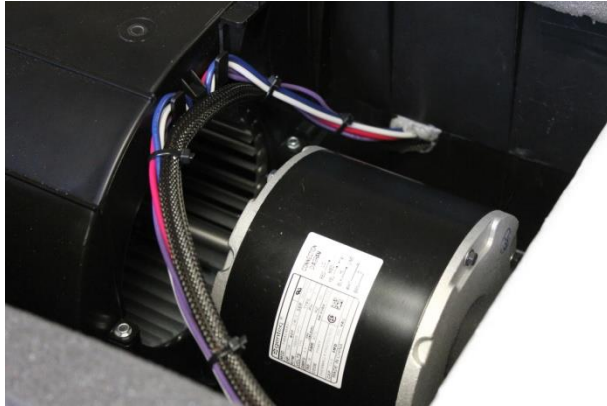

Figure 29

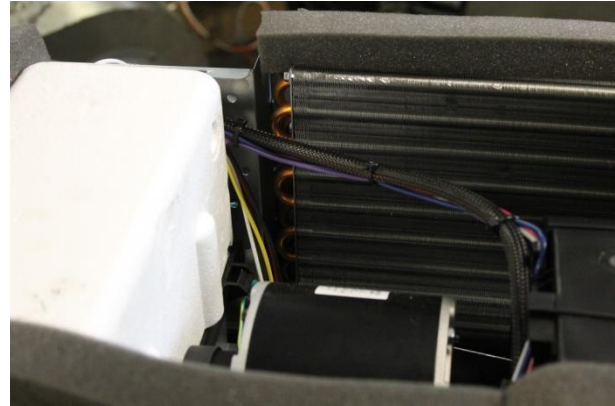

Figure 28

Use wire ties to tie the braided cable to the wire harness at several locations, Figure 28 and Figure 29.

Note: Do not route the wires over the top of the foam. A good seal is necessary and compromising this seal can cause the compressor to overheat and trip its protection device.

Remove the electrical box cover. Remove the factory strain relief where the wires pass into the top of the box from the compressor and motor. Squeeze the back side of the relief and push it through the hole to remove it as shown in Figure 30.



Figure 30

Install the split plastic bushing provided in the kit. The split allows it to slide over the existing wires without having to disconnect them. Snap it into place in the existing hole. Once the bushing is in place, route the wires from EasyStart through the hole, Figure 31.



Figure 31

Making the connections

Use only end splice or jacketed spade connectors for connecting one wire to another. Wire nuts can come off in this high vibration environment and automotive connectors are not rated for line voltage.

Brown wire

Follow the white wire from the compressor into the electric box to the top of the run capacitor. Disconnect the white wire and cut off the connector on the end. Strip about ½ inch (1.27cm) of insulation from the white wire and from the BROWN wire from EasyStart. Twist both wires together and crimp them with an end splice connector as shown in Figure 32.

Note: *Some installations will have multiple white wires on the terminal group. Be sure to follow the white wire from the compressor completely back to the run capacitor.*



Figure 32

White wire

Place a yellow female quick-connect terminal on the WHITE wire from EasyStart and crimp tightly. Connect the WHITE wire from EasyStart to the run capacitor on the same terminal group as the other white wires on the “C” terminal, shown by the green arrow in Figure 33.

Orange wire

Place a blue female quick-connect terminal on the ORANGE wire from EasyStart and crimp it tightly. Connect the ORANGE wire to the red wire terminal group on run capacitor shown by the orange arrow in Figure 33.

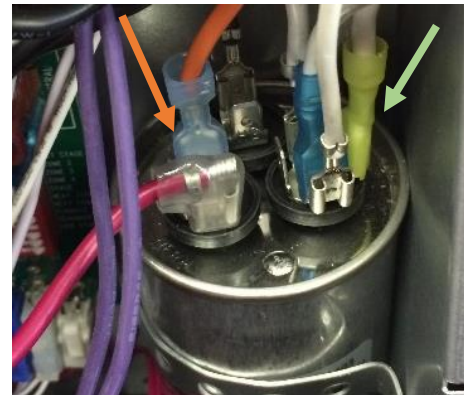

Figure 33

Black wire

There are two configurations for connecting the blue wire in a Penguin air conditioner. The first has a control board mounted inside the electrical box. The blue wire simply passes through the electrical box in the second configuration.

1. Control board in box: Install a blue angled quick connect on the black wire provided in the installation kit. Disconnect the blue wire from the relay on the control board and plug in the blue angled quick connect. Cut the connector off of the blue wire. Splice together, the blue wire, the black wire from EasyStart and the black installation kit wire using an end splice. Shown in Figure 34.
2. No Control board: Cut the blue wire in a convenient location. Splice the two blue ends and the black wire from EasyStart together using an end splice.



Figure 34

Removing existing start components

Some systems may use a start capacitor and PTCR as shown in Figure 35. Previous owners may have also installed a hard start kit that replaces these components. These components form a circuit that connect from the white wire group on the run capacitor to the red wire group on the run capacitor. If your run capacitor has only a single red wire to the compressor connected to the HERM terminal group you can skip to the next step as the system doesn't have start components.



Figure 35

Remove the PTC and start capacitor from the electrical box. The PTC is the small device with the wire plugged into each end. It unsnaps from a clip in the box. The start capacitor is in the bottom of the electrical box. It is held in by a single hex nut and band that goes around the capacitor. The red and white wires go to terminals on the run capacitor and are removed from these terminals.

Heat Pumps: *If there is an extra wire (usually black or purple and not shown in Figure 35) on the start capacitor, disconnect it from the start capacitor and connect it to the run capacitor "C" terminal group.*

Blizzard NXT

Wiring Diagrams

Figure 36 is a wiring diagram for the NXT. There are 4 variants of the wiring diagram with different formatting but all are electrically the same for an EasyStart installation, with the same wire colors and relevant components. The red X's indicated components or wires that must be removed during EasyStart installation.

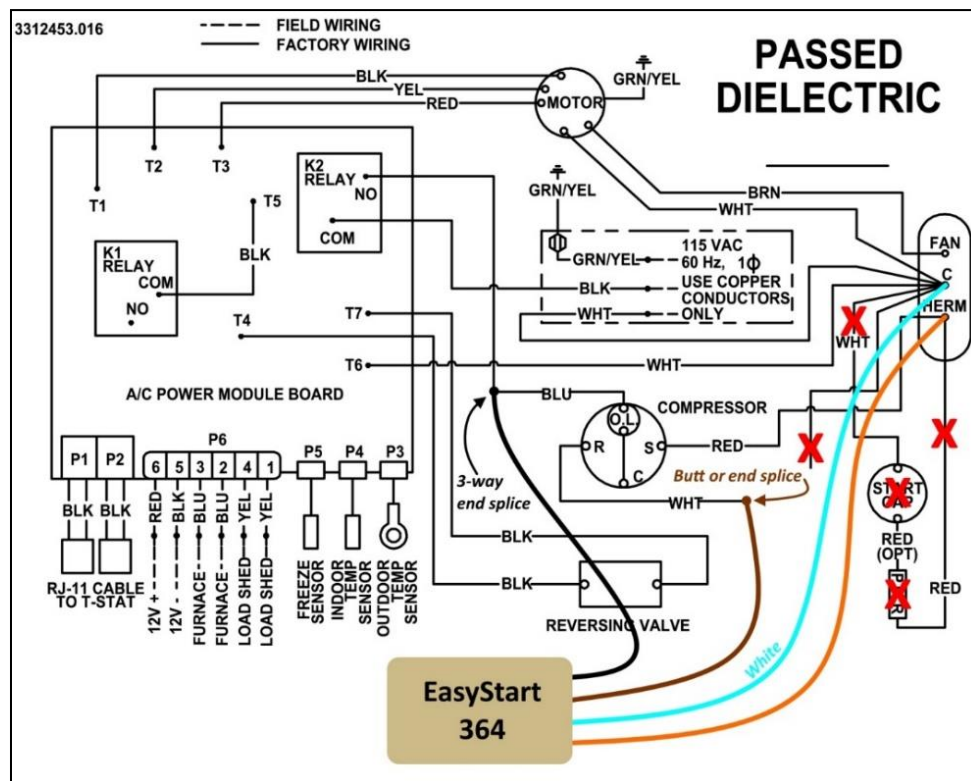

Figure 36

Figure 36 shows a heat pump option with the reversing valve. If you have a heat pump and there is more than 1 wire on either terminal of the start capacitor, move this third reversing valve wire (usually a black or purple wire) to the “C” terminal on the run capacitor when disconnecting the start capacitor as shown. **Note: none of the 4 mentioned schematics show this but could be potentially found.**

NXT Mounting Location



Figure 37

Figure 37 shows a potential mounting location for EasyStart. Included in the installation kits are alcohol wipes and double-sided foam tape. Use alcohol to clean the foam surface. Place one side the tape halves on the top and bottom of the EasyStart back and affix it to the cleaned foam location. Once the connections are made (below) you can zip tie the excess EasyStart wire loom as shown.

Routing the wires

Pull back the grey or black putty around the wires that pass the compressor wires through the plastic air box separator, shown in Figure 38. Pass the braided wires from EasyStart through the hole and form the putty back around the wires and over the hole.



Figure 38

Use wire ties to tie the braided cable to the wire harness at several locations around the electric box.

Note: Do not route the wires over the top of the foam. A good seal is necessary and compromising this seal can cause the compressor to overheat and trip its protection device.

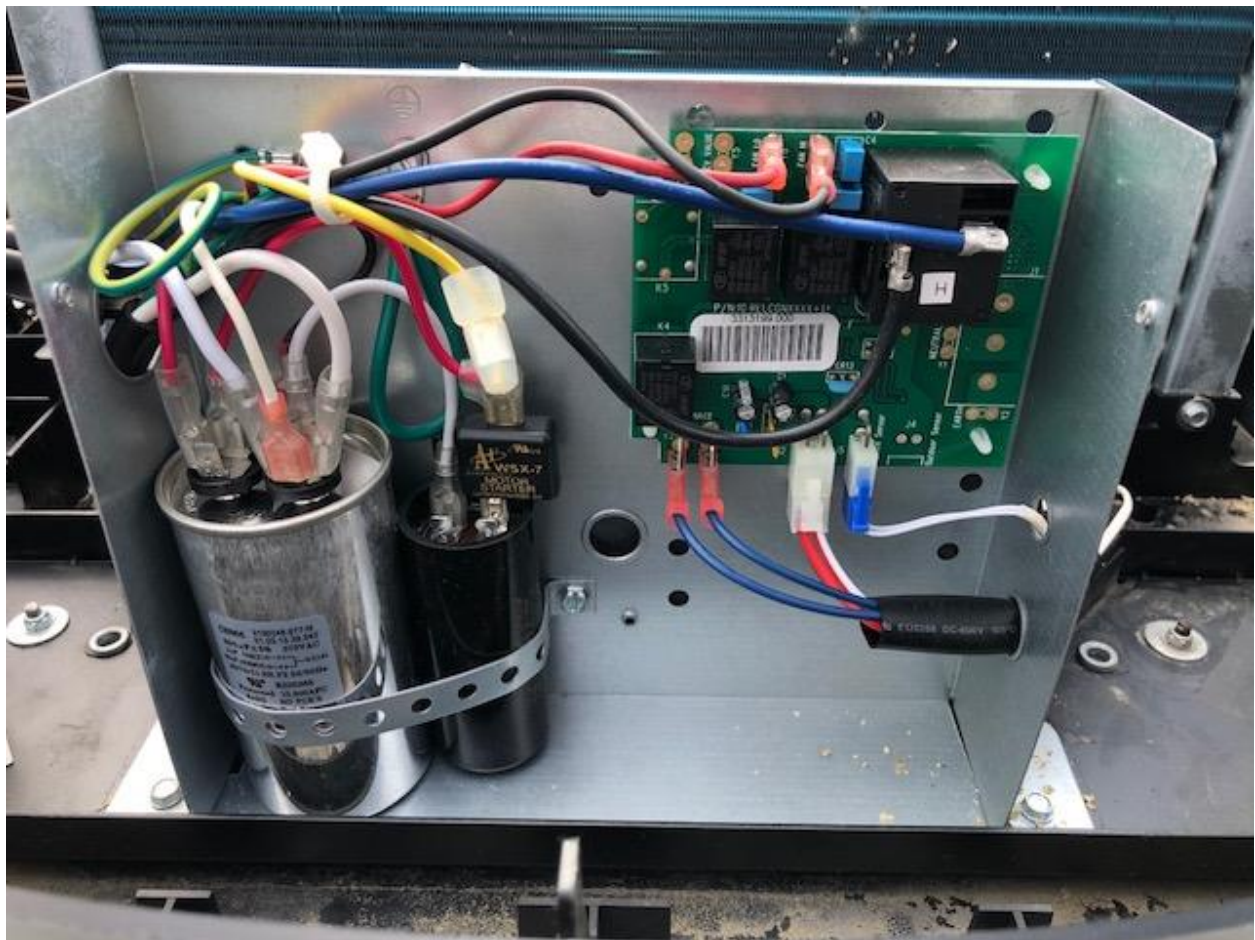

Figure 39

Remove the electrical box cover. Remove the factory strain relief where the wires pass into the top of the box from the compressor and motor. Squeeze the back side of the relief and push it through the hole to remove it.

Install the split plastic bushing provided (if needed) in the kit. The split allows it to slide over the existing wires without having to disconnect them. Snap it into place in the existing hole. Once the bushing is in place, route the wires from EasyStart through the hole. Figure 39 shows a factory, opened electric box and where you can feed wires through in the top left. Figure 41 shows an installed EasyStart.

Making the connections

Use only end splice or jacketed spade connectors for connecting one wire to another. Wire nuts can come off in this high vibration environment and automotive connectors are not rated for line voltage.

Brown wire

Follow the white wire from the compressor into the electric box to the top of the run capacitor. Disconnect the white wire and cut off the connector on the end. Strip about ½ inch (1.27cm) of insulation from the white wire and from the BROWN wire from EasyStart. Twist both wires together and crimp them with an end splice connector as shown in Figure 40 and the brown arrow in Figure 41.

Note: Some installations will have multiple white wires on the terminal group. Be sure to follow the white wire from the compressor completely back to the run capacitor.



Figure 40

White wire

Place a yellow female quick-connect terminal on the WHITE wire from EasyStart and crimp tightly. Connect the WHITE wire from EasyStart to the run capacitor on the same terminal group as the other white wires on the "C" terminal.

Orange wire

Place a blue female quick-connect terminal on the ORANGE wire from EasyStart and crimp it tightly. Connect the ORANGE wire to the red wire terminal group on run capacitor shown by the orange arrow in Figure 41.

Black wire

Control board in box: Install a blue angled quick connect on the black wire provided in the installation kit. Disconnect the blue wire from the relay on the control board and plug in the blue angled quick connect. Cut the connector off of the blue wire. Splice together the blue wire, the black wire from EasyStart and the black installation kit wire using an end splice. Shown (without end splice) by blue arrow in Figure 41.

No Control board: Cut the blue wire in a convenient location. Splice the two blue ends and the black wire from EasyStart together using an end splice.



Figure 41

Removing existing start components

Some systems may use a start capacitor and PTCR as shown in Figure 42. Previous owners may have also installed a hard start kit that replaces these components. These components form a circuit that connect from the white wire group on the run capacitor to the red wire group on the run capacitor. If your run capacitor has only a single red wire to the compressor connected to the HERM terminal group you can skip to the next step as the system doesn't have start components.

Remove the PTC and start capacitor from the circuit. The PTC is the small device on the start capacitor where the red wire enters. These start capacitor red and white wires go to terminals on the run capacitor and must be removed.

Heat Pumps: If there is an extra wire (usually black or purple, shown as purple in Figure 42) on the start capacitor, disconnect it from the start capacitor and connect it to the run capacitor "C" terminal group.



Figure 42

Learning process

EasyStart “Learns” the start characteristic for your compressor over the first five starts. We recommend that these starts are done on a 20 amp or greater utility power source with all other loads in the RV turned off.

Installations that do not have access to utility power can do the learn process on a generator, but with some risk of improper learning and it is not recommended on very marginal power sources. Generators must have a continuous rated output capable of supporting the air conditioner. Any low RPM economy or ECO mode must be switched off so the compressor can start with the maximum starting capacity of the generator.

The best power source is one that you have reliably run the air conditioner from before installing EasyStart.

Steps:

1. Breaker on the air conditioning unit.
2. Set the thermostat to start the air conditioner compressor. Heat mode may be used if you are using a heat pump model.
3. The compressor will start up shortly after the fan starts. Let the compressor run for 30 seconds.
4. Set the thermostat to turn off the compressor.
5. Set the thermostat to start the compressor again.
6. EasyStart will wait 3 minutes from the time the compressor stopped in step 4 to restart the compressor.
7. The compressor will start up shortly after the fan starts. Let the compressor run for 30 seconds.
8. Set the thermostat to turn off the compressor.
9. Repeat steps 5 to 8 three more times to complete the learn process.

Once the learn process is complete, EasyStart does not learn again. EasyStart can now be used on generators, inverters or utility power to provide low-current starts every time.

Troubleshooting FAQ

How do I know I installed it correctly?

EasyStart has a few characteristics that can help you determine that. First, the compressor should start more quietly than it did before. Lights will dim much less and if you have a volt or current meter you should see a measurable difference.

Second, if you turn off the compressor at the thermostat when it is running then turn it on right away, EasyStart will prevent the compressor from starting for three minutes. If the compressor starts sooner, you have a wiring problem.

Nothing works, not even the fan.

EasyStart does not affect the fan at all. If the fan does not run then most likely you connected the wrong white wire to the brown wire. Check it again and make sure the wire connected to the brown wire is the white wire that comes from the compressor.

The fan runs but it won't start on utility power.

1. Go through these directions again and verify every connection.
2. Be sure you turned on all the power you turned off. Some thermostats need DC to operate as well as AC.
3. Check the thermostat set point. If you have a digital thermostat the ambient temperature must be above the set point for the air conditioning to work. If it's a slide thermostat, it must be set for full cool.
4. Is it too cold for the compressor to start? We often get calls where a slide thermostat will not work under 70°F (21.2°C) ambient. Try heat mode if you have a heat pump and it is too cold or warm the RV with the heater first.
5. Check your line voltage when the compressor tries to start and make sure it is not dropping below 108 VAC. Some RV's have surge suppressors that cut off on low voltage. Long or undersized AC line cords can also cause starting problems.

I did everything in the last FAQs and it still will not start. What next?

Go to the Micro-Air.net website and download "Advanced EasyStart Troubleshooting". Follow the steps given to determine the possible problems.

My air conditioner runs great on commercial electric power but will not start on my generator.

Be sure all the loads are turned off in your RV. A 15K BTU air conditioner will use about 1800-1900 watts to run leaving no additional capacity for any other loads on a 2000-watt generator. Be sure you check generator reviews before you chose a generator. Not all generators can run an air conditioner.

My air conditioner shuts off early on generator. What can be wrong?

Aside from the suggestions in the last questions, you should also test your generator output and verify the RV load. We offer a generator test kit on Microair.net. The associated manual is available from the test kit purchase page and has the complete test and additional things to look for.

Copyright ©2020 Micro-Air Corporation

No part of this publication may be reproduced, translated, stored in a retrieval system, or transmitted in any form or by any means electronic, mechanical, photocopying, recording or otherwise without prior written consent by Micro Air Corporation.

Every precaution has been taken in the preparation of this manual to insure its accuracy. However, Micro Air Corporation assumes no responsibility for errors and omissions. Neither is any liability assumed nor implied for damages resulting from the use or misuse of this product and information contained herein.